

50m Fire Hose Reel



FEATURES

- One-year warranty from date of delivery
- Economically priced
- Simple operation and maintenance
- Meets or exceeds requirements of Australian standard AS1221

ORDERING INFORMATION

For the protection assistance, see your nearest authorised Isupply (Australia) Pty Ltd distributor or sales representative

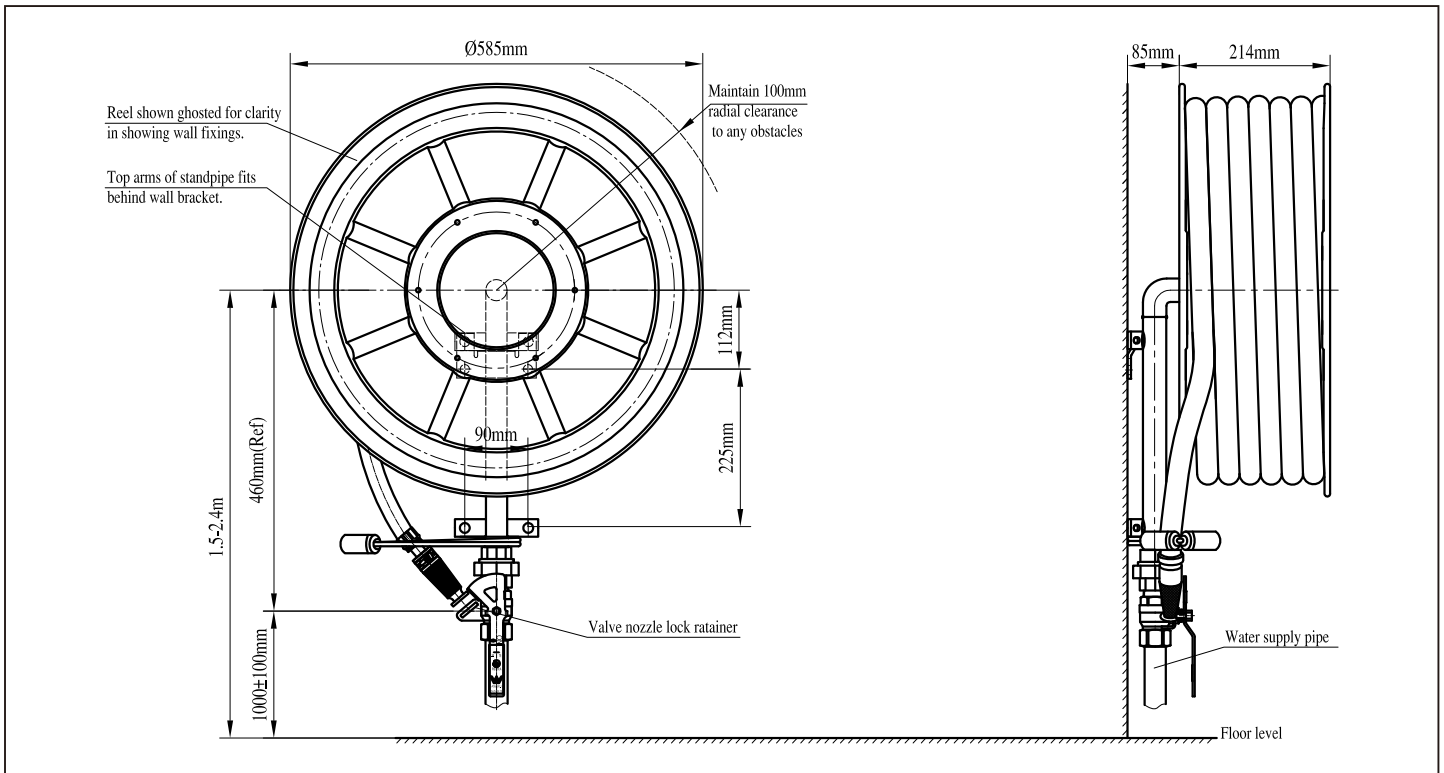

Item	Description	Item	Description
Model Number	HS5019-585	Support Assembly	Mild Steel, Galvinised
Part Number	RH301921H	Hoseguide Assembly	Stainless Steel
Standard HoseLength&Dia	50meters X19mm Dia	Union	Malleable Iron, Galvanised
Approvals	AS/NZS 1221	Ball Valve Assembly	Brass / Mild Steel Handles
Minimum Inlet Pressure	220kPa	Nozzle Assembly	Brass
Maximum Working Pressure	1.0MPa	Drum	Polypropylene Copolymer
Side Plates	Steel Sheet Shoving Enamel Red	Hose Spring	Galvanised Spring Steel
Gland	Acetal Copolymer	Tailpiece	Acetal Copolymer
Spindle	Mild Steel	Circlip	Galvanised Spring Steel
Bearing	Acetal Copolymer	Inlet Pivot Pipe	Galvanised Mild Steel Pipe
Elbow	Malleable Iron, Galvanised	Wall bracket	Mild Steel

50m Fire Hose Reel

Component Details

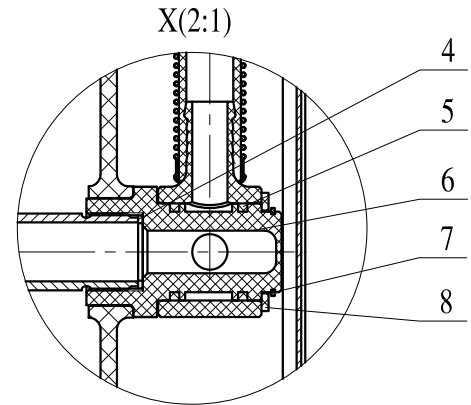
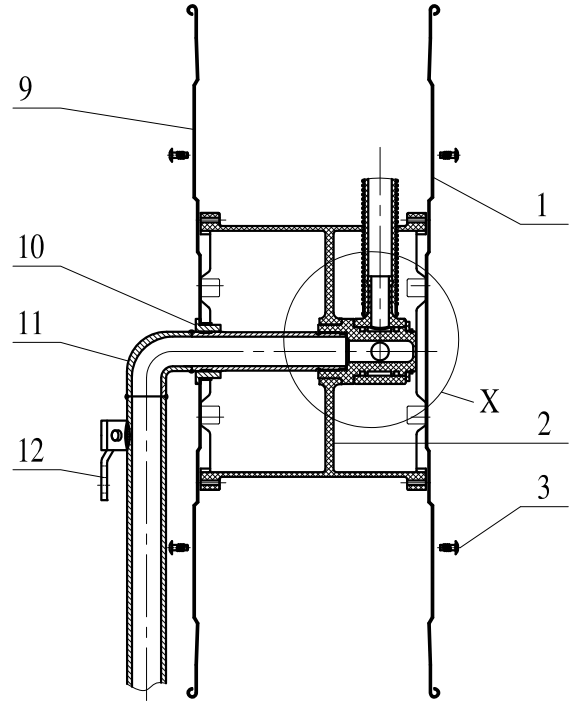
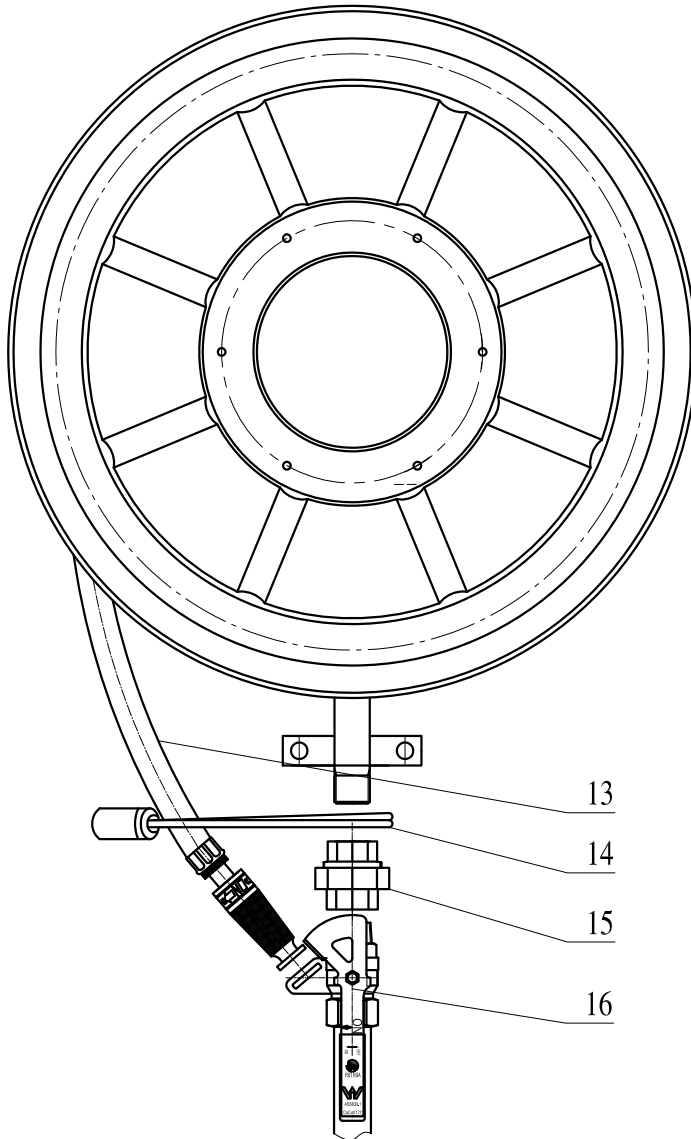

N0.	Part No.	Description	N0.	Part No.	Description
16	RH500105T	Ball Valve Assembly	3	RH301917-10	Screw
15	/	Union	2	RH301917-9	Drum
14	RH301917-5	Hose Guide Assembly	1	RH301921-2	Side Plate Outer
13	RH300447B	Hose Assembly			
12	RH301917-4	Wall Bracket			
11	RH301917-3	Support Assembly			
10	RH301917-6	Bearing			
9	RH301921-1	Side Plate Inner			
8	RH301917-8	Retaining Washer			
7	GB/T894.2-1986	Circlip			
6	RH301917-7	Gland Inner			
5	RH301917-11	Gland Seal Quad Rings			
4	RH301917-12	Gland Seal Washer			

Distributed By:

Isupply (Australia) Pty Ltd
 4/3-5 Natalia Ave, Oakleigh South, VIC 3167
 Email: info@isupplyaustralia.com.au
www.isupplyaustralia.com.au